

DIMENSIONS OF BUCKET

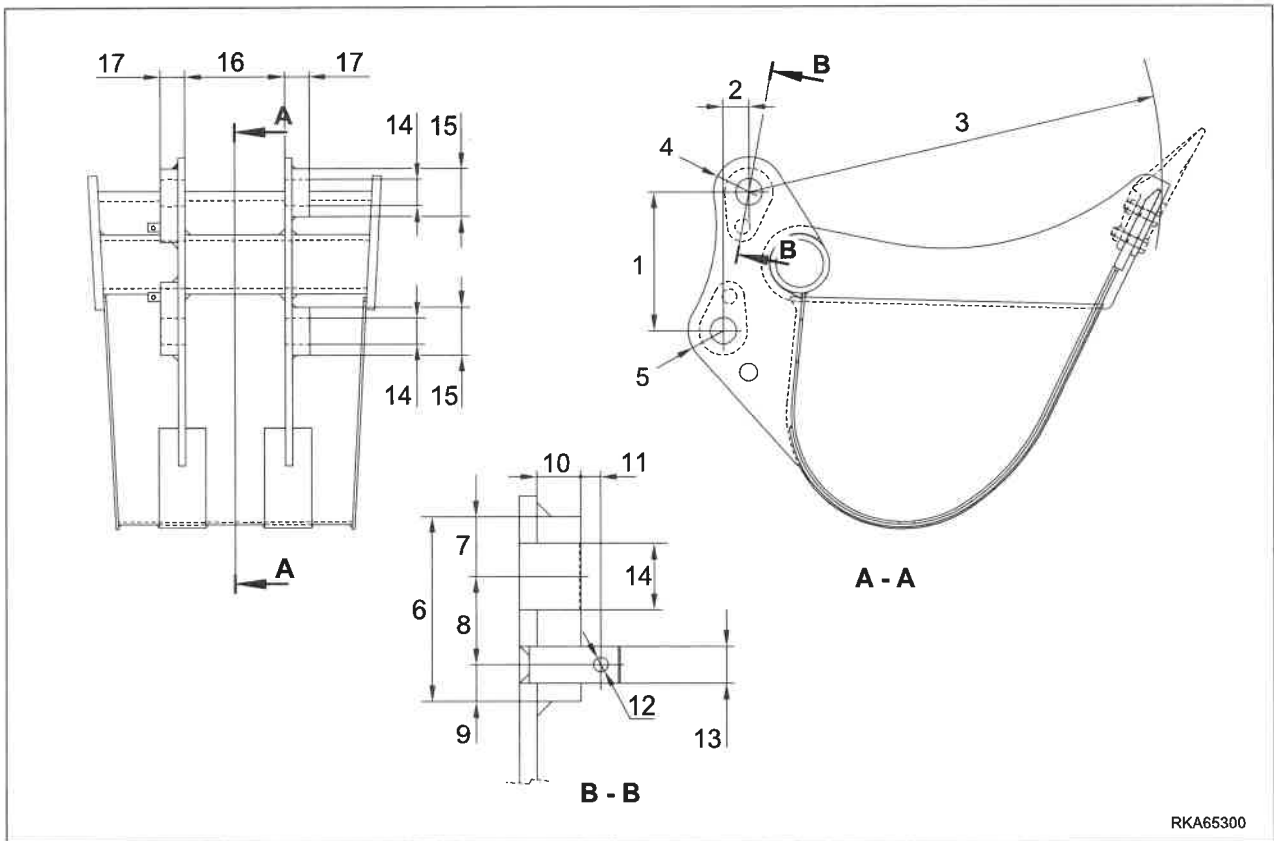

RKA65300

Unit: mm

PC45MR-5M0, PC55MR-5M0			
No.	Measuring point	Standard dimension	Tolerance
1	-	237.1	-
2	-	44.1	-
3	-	700	-
4	-	60	-
5	-	60	-
6	-	128 °	-
7	-	41 °	-
8	-	60	+0 +0.5
9	-	25	-
10	-	30	-
11	-	13.5	-
12	-	10	-
13	-	25	-
14	-	45	-0.106 -0.145
15	-	45	-

Unit: mm

No.	PC45MR-5M0, PC55MR-5M0		
	Measuring point	Standard dimension	Tolerance
16	-	170	±1
17	-	42	-